



Gooch & Housego



OL FEL High-accuracy Irradiance Standard

PERFORMANCE SPECIFICATIONS

Spectral Irradiance (nominal)	
@ 250 nm	0.03 $\mu\text{W}/\text{cm}^2\text{nm}$
@ 1000 nm	25 $\mu\text{W}/\text{cm}^2\text{nm}$
Total Irradiance (nominal) 32 mW/cm ²	
Illuminance (nominal)	800 footcandles
Transfer Uncertainty*	
High accuracy	$\pm 1\%$
Super High-accuracy	$\pm 0.5\%$
Uncertainty* - Illuminance	$\pm 1\%$
Long Term Stability**	< 0.06%/ hour
Operating Current	8.00 amps DC

* Uncertainty is relative to NIST Scale
 ** High Stability option available

Gooch and Housego offers 1000-W FEL type lamps as standards of spectral irradiance, total irradiance, Illuminance, and color temperature. These lamps have a tungsten coiled-coil filament enclosed in a small quartz envelope. The lamp bases have been converted to a medium bi-post base as recommended by the National Institute of Standards and Technology (NIST). This special lamp base improves alignment accuracy, which minimizes uncertainties due to positioning and orientation of the lamp.

The spectral irradiance standards issued by Gooch and Housego can be obtained with spectral irradiance calibrations over all or part of the entire 250 to 4500 nm wavelength region. Calibrations are based on the NIST Spectral Irradiance Scale for the wavelength range of 250 to 2400 nm and on a copper freezing point blackbody for the wavelength range above 2400 nm. The NIST Scale has an uncertainty of 1% in the visible, 2.5% in the ultraviolet at 250 nm, and 3% in the infrared at 2000 nm.

Calibrations over the wavelength range of 250 to 2400 nm are available with two levels of accuracy: high-accuracy and super high-accuracy. The High-accuracy FEL Standards issued by Gooch and Housego have a transfer uncertainty relative to the NIST Scale of $\pm 1\%$. The Super High-accuracy FEL Standards have a transfer uncertainty relative to the NIST Scale of $\pm 0.5\%$.

CALIBRATION OPTIONS

Spectral Irradiance: 250 – 750 nm.....	OL FEL-A
Spectral Irradiance: 750 – 2500 nm.....	OL FEL-B
Spectral Irradiance: 250 – 2500 nm.....	OL FEL-C
Spectral Irradiance: 250 – 1100 nm.....	OL FEL-M
Spectral Irradiance: 250 – 4500 nm.....	OL FEL-IR
Total Irradiance	OL FEL-D
Total and Full Spectral	OL FEL-H
Illuminance (only)	OL FEL-P
Color Temperature (only)	OL FEL-K
Uncalibrated (seasoned)	OL FEL-U

For Illuminance and/or color temperature calibrations in addition to any of the above calibrations, add the suffix "P" and /or "K" respectively to the appropriate model number.

For super high-accuracy calibrations, add the suffix "S" to the appropriate model number.

OPTIONAL ACCESSORIES

Lamp Holder	OL 61
FEL Alignment Jig	OL 62
Adjustable Lamp Holder Mount	OL 63
Programmable Current Source	OL 83A

Contact: sales@goochandhousego.com

www.goochandhousego.com

As part of our policy of continuous product improvement, we reserve the right to change specifications at any time



Method of Calibration

The instrumentation and technique used by Gooch & Housego to transfer calibrations from a standard of spectral irradiance to an uncalibrated lamp is patterned after that used at NIST. The measurement procedure employs the highly accurate wavelength-by-wavelength method of comparison (Figure 1). This minimizes the errors associated with setting the lamp current, distance, wavelength, and repeatability.

In this technique, both lamps (standard and test) are operated in series at the same current and at the same distance. The spectral irradiance of both lamps is measured at a set wavelength by translating the double monochromator along the optical bench to view each source. A wavelength-by-wavelength comparison is made at all of the NIST calibration wavelengths.

The high-accuracy FEL standards are calibrated by comparison to a standard that was calibrated directly against a NIST standard. The super high accuracy FEL standards are compared directly to a NIST standard.

Optional Accessories

Gooch & Housego offers several accessories to enable the user to realize the high accuracy assigned to their NIST-traceable standard. These accessories are designed to minimize errors due to current setting, alignment, and orientation.

The OL 83A programmable Current Source is specifically designed for operating the 1000-W lamp standards at the exact current.

There are six dimensional variables involved in the NIST recommended alignment of a lamp relative to the instrument. The OL 61 Lamp Holder, OL 62 FEL Alignment Jig, and OL 63 Adjustable Lamp Holder Mount (Figure 2) are designed to allow the user to control the physical positioning of the lamp including distance, horizontal distance, vertical distance, pitch (tilt), yaw (rotation), and roll.

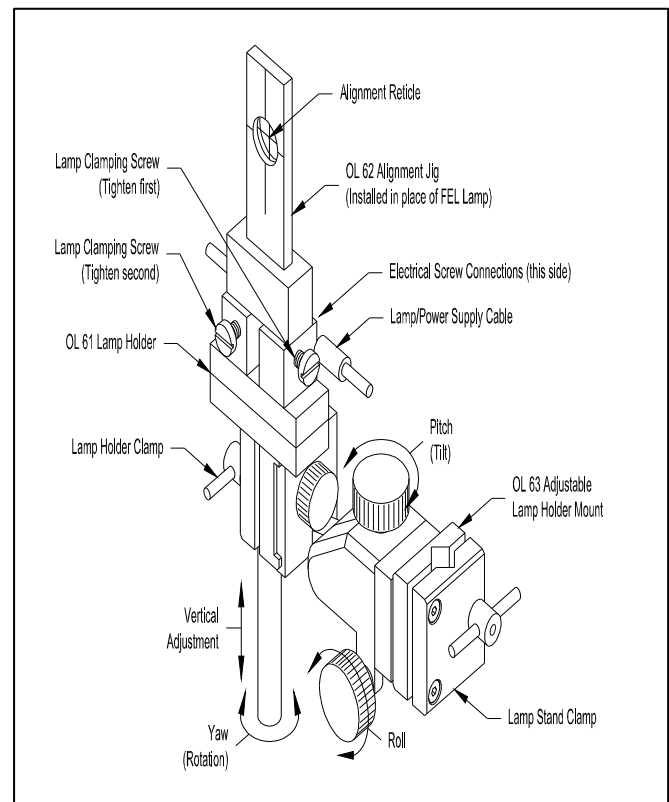
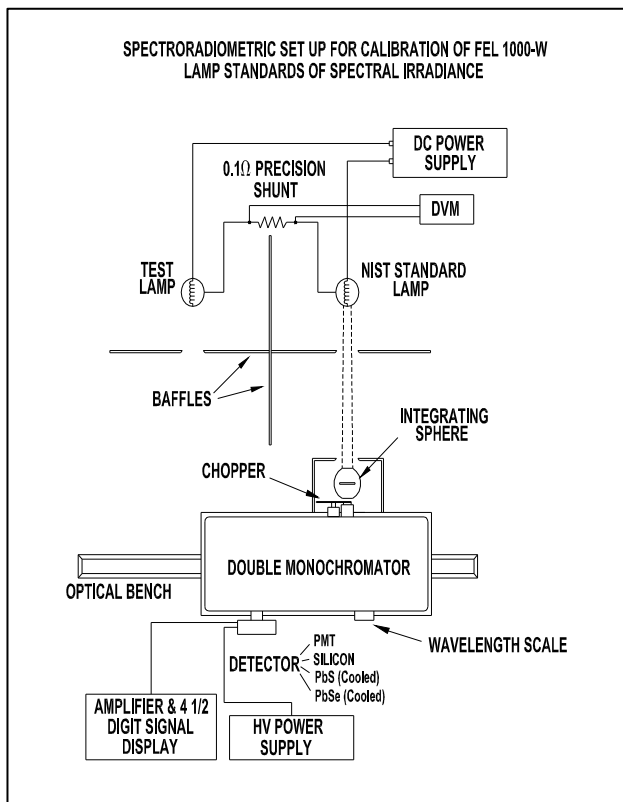

Contact: sales@goochandhousego.com

www.goochandhousego.com

As part of our policy of continuous product improvement, we reserve the right to change specifications at any time

